

Statics

Question: 1.

A 20 kg mass is placed on a smooth plane that is inclined at 30° to the horizontal, as shown in the diagram below. A force of 100 N is applied to the mass up the slope at an angle of θ° to the slope.

Find the magnitude of the angle θ such that the system is in equilibrium. Give your answer correct to 1 decimal place.

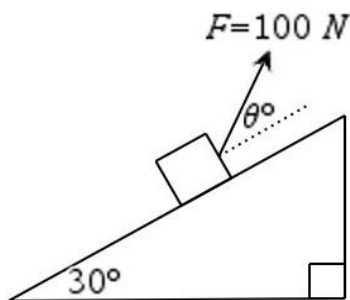

Question: 2.

A 30 kg mass is placed on a rough plane that is inclined at 60° to the horizontal, as shown in the diagram below. A force of 60 N is applied to the mass up the slope and parallel to the slope. There is also a frictional resistance force of magnitude F that opposes the motion of the mass.

Find the magnitude of the frictional resistance force, in newtons, acting down the slope if the friction resistance force is sufficient to stop the mass from moving up the slope.

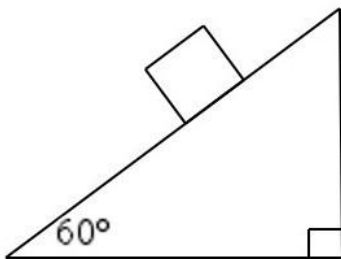

Question: 3.

A mass of m kilograms is held in equilibrium by two ropes. The first rope makes an angle of 30° to the horizontal and has a tension of T_1 newtons. The second rope makes an angle of 60° to the horizontal and has a tension of T_2 newtons.

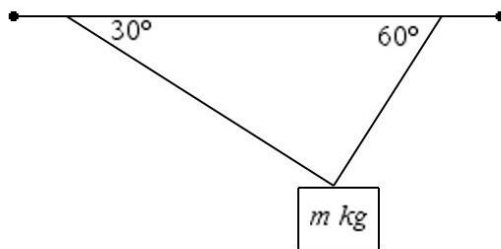

- Show that $T_2 = \sqrt{3} T_1$
- The first rope will break if the tension in it exceeds 49 N . Find the maximum value of m for which the mass will remain in equilibrium.

Question: 4.

- A 4 kg mass on a smooth inclined plane is attached to a light inextensible string that passes over a smooth pulley to a 2 kg mass hanging over the side, as shown. The system is in equilibrium. Find the angle the plane makes with the horizontal.

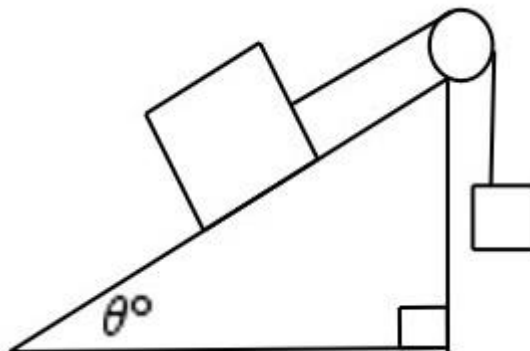

- A 1 kg mass is now connected to the 2 kg mass via a rope. Find the required angle that the plane needs to make with the horizontal for the system to be in equilibrium. Give your answer correct to 1 decimal place.

Question: 5.

A 20 kg mass is suspended by two strings, as shown in the diagram below.

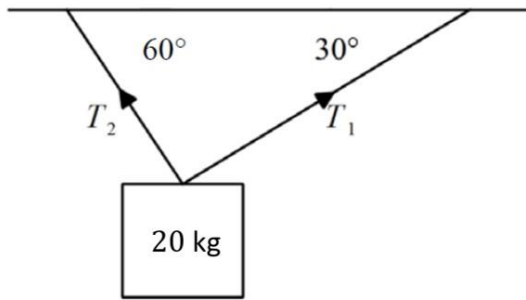

a. Calculate the tension, in newtons, in each rope given that the system is in equilibrium.

The string with tension T_2 is connected to a second mass of 20 kg positioned on a smooth incline, over a smooth pulley. The system can be represented by the diagram below.

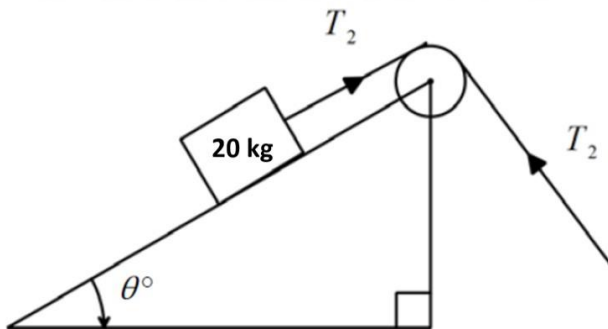

b. Calculate the value of θ if the 20 kg mass remains stationary.

Question: 6.

A 10kg mass on a smooth inclined plane is attached to a light inextensible string that passes over a smooth pulley to a mass of m kg hanging over the side, as shown. The m kg mass is connected to a 2 kg mass via another string. Find the value of m for which the system is in equilibrium.

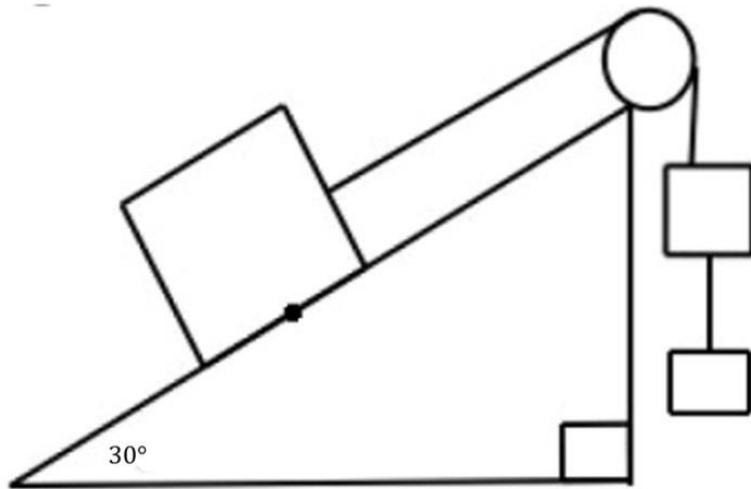

Question: 7.

Two masses are at rest on two smooth inclined planes, inclined at angles of θ_1 and θ_2 to the horizontal respectively. The masses are connected by a rope which passes over smooth pulley, as shown below.

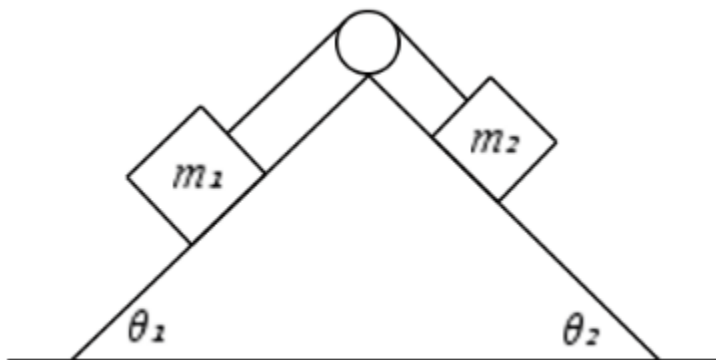

- Show that $\frac{m_1}{m_2} = \frac{\sin(\theta_2)}{\sin(\theta_1)}$
- Given that $\theta_1 = 2\theta_2$, show that $\frac{m_1}{m_2} = \frac{1}{2} \sec(\theta_2)$

Answers

Question 5 a. $T_1 = 10\sqrt{3}g$ $T_2 = 10g$

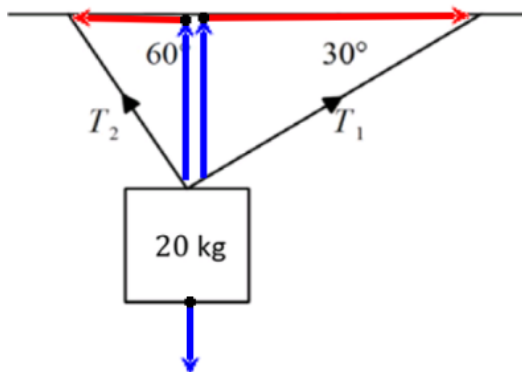

$$\text{solve} \left(\begin{cases} t1 \cdot \cos(30) = t2 \cdot \cos(60) \\ t2 \cdot \sin(60) + t1 \cdot \sin(30) = 20 \cdot g \end{cases}, \{t1, t2\} \right)$$

$$t1 = 10 \cdot g \text{ and } t2 = 10 \cdot g \cdot \sqrt{3}$$

Label all of your forces acting on the object and resolve the tension forces into horizontal and vertical components

$\Sigma F = 0$ horizontally

$$T_1 \cos(30) = T_2 \cos(60)$$

$\Sigma F = 0$ vertically

$$T_2 \sin(60) + T_1 \sin(30) = 20g$$

$$T_1 = 10\sqrt{3}g$$

$$T_2 = 10g$$

b. $\theta = 30^\circ$

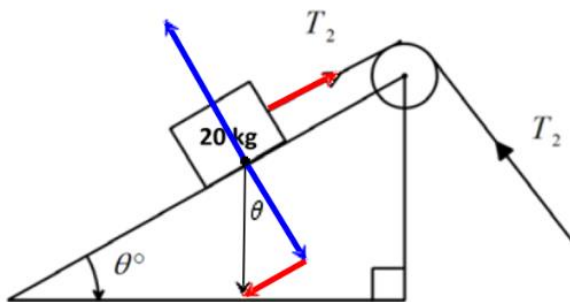

$$\text{solve} \left(\begin{cases} t2 = 20 \cdot g \cdot \sin(\theta) \\ t2 = 10 \cdot g \end{cases}, \{ \theta \} \right) \mid 0 \leq \theta \leq 90 \text{ and } g = \rightarrow$$

$$\theta = 30. \text{ and } t2 = 98.$$

Identify and label all forces acting on the 20 kg object. Resolve the Weight force into parallel and perpendicular components to the plane.

$\Sigma F = 0$ horizontally

$$T_2 - 20g \sin(\theta) = 0$$

From 5a., $T_2 = 10g$

Substituting the second equation into the first gives

$$10g = 20g \sin(\theta)$$

$$\sin(\theta) = \frac{1}{2}$$

$$\theta = 30^\circ$$

Question 6

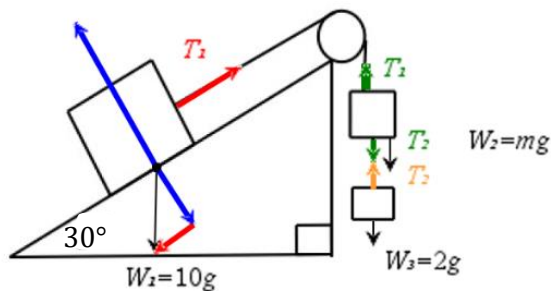

Identify and label all forces acting on the 10 kg object, the m kg object, and the 2 kg object. Resolve the Weight force into parallel and perpendicular components to the plane, and resolve forces vertically for the m kg and 2 kg objects.

Consider the forces acting on each object.

For the 10 kg mass:

$$\sum F = 0 \text{ horizontally}$$

$$T_1 - 10g \sin(30) = 0$$

For the m kg mass:

$$\sum F = 0 \text{ vertically}$$

$$T_1 - T_2 - mg = 0$$

For the 2 kg mass:

$$\sum F = 0 \text{ vertically}$$

$$T_2 - 2g = 0$$

Solving simultaneously gives $m = 3$

$$\text{solve } \begin{cases} t1 - 10 \cdot g \cdot \sin(30) = 0 \\ t1 - m \cdot g - t2 = 0 \\ t2 - 2 \cdot g = 0 \end{cases}, \{ m \} | g = 9.8$$

$m = 3$, and $t1 = 49$, and $t2 = 19.6$

Question 7

a.

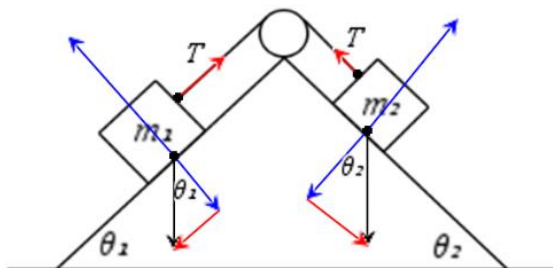

Identify and label all forces acting on the two objects. Resolve the Weight forces into parallel and perpendicular components to the plane.

For the m_1 mass:

$$\sum F = 0 \text{ horizontally}$$

$$T = m_1 g \sin(\theta_1)$$

For the m_2 mass:

$$\sum F = 0 \text{ horizontally}$$

$$T = m_2 g \sin(\theta_2)$$

Substituting the first equation into the other gives

$$m_1 g \sin(\theta_1) = m_2 g \sin(\theta_2)$$

Rearrange to make $\frac{m_1}{m_2}$ the subject, as required.

b.

$$\frac{m_1}{m_2} = \frac{\sin(\theta_2)}{\sin(\theta_1)}$$

Substitute in $\theta_1 = 2\theta_2$. This will give

$$\frac{m_1}{m_2} = \frac{\sin(\theta_2)}{\sin(2\theta_2)}$$

Applying the sine double angle formula results in

$$\frac{m_1}{m_2} = \frac{\sin(\theta_2)}{2 \sin(\theta_2) \cos(\theta_2)}$$

$$\frac{m_1}{m_2} = \frac{1}{2} \sec(\theta_2)$$